



Photovoltaics in the UK:

An introductory guide for new consumers

Dr Christian N Jardine

Dr Kevin Lane

Environmental Change Institute

University of Oxford





John Boardman

Burning fossil fuels for power has caused increased levels of carbon dioxide in the atmosphere.

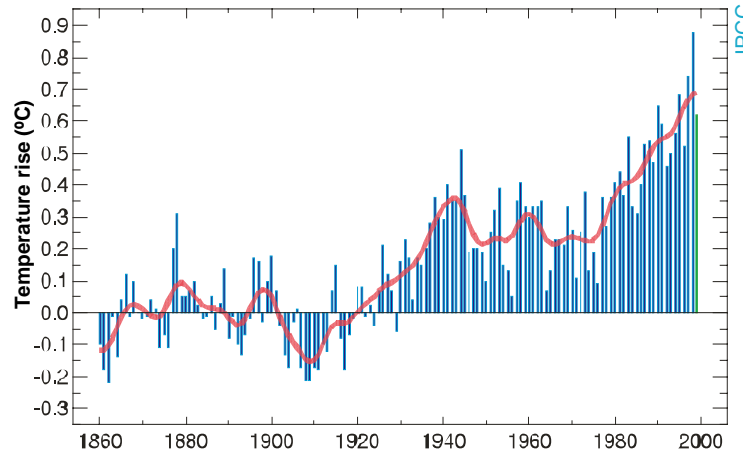

IPCC

Average global temperature is rising rapidly. Nine of the world's warmest years since records began occurred since 1990.



Christian Jardine

Installing photovoltaics, which harness solar energy, reduces CO₂ emissions.

Using solar energy reduces climate change

- Over the next century, solar power is predicted to become an important energy source for mankind. It is already possible to generate electricity from the power of the sun in your own home, and it is environmentally friendly too.
- Man-made emissions of carbon dioxide (CO₂) from burning fossil fuels, and other greenhouse gases are causing major changes to the planet's climate.
- The average world temperature is predicted to rise by between 1.8 and 5.8 °C by 2100, with regional variations even more extreme.
- This global warming will also induce severe climatic events, including storms, flooding, drought and the resultant ecosystem changes. The consequences for agriculture, industry and the economy could be very severe.
- The Rio Earth Summit agreed to limit atmospheric greenhouse gas emissions to a level where ecosystems are not threatened by climate change.
- This was formalised in the Kyoto Protocol, which set legally binding targets. The UK's target is to reduce greenhouse gas emissions by 12.5% from 1990 levels by 2010.
- In the longer term, the Royal Commission on Environmental Pollution has recommended that the UK should reduce CO₂ emissions by 60% by 2050. Meeting such targets is a major challenge to all sectors of society, especially when energy use is still rising due to increased transport, a successful economy and increased consumption in the domestic sector.
- Solar energy is one of a range of renewable energy technologies that can produce electricity without greenhouse gas emissions. These must form a major proportion of UK energy supply if targets are to be met and expansion of nuclear power is to be avoided.



Christian Jardine

Photovoltaics produce clean green electricity from daylight.

Photovoltaics produce electricity from daylight. Direct sunshine is not necessary.



Solar Century

Photovoltaics can be incorporated into buildings, and generate electricity within towns and cities.

What are photovoltaics?

- Photovoltaics (PVs) are simply devices that convert the energy of light directly into electricity.
- They are made from semiconducting materials such as silicon. Silicon is the second most abundant element in the earth's crust and is a truly sustainable resource. It is most commonly found in sand.
- Photovoltaics will produce electricity when light shines on them. Although more electricity is produced when it is sunny, much energy can still be produced under overcast conditions.
- Photovoltaics are guaranteed to last 10-20 years, but are expected to last at least 25 years.

Why should we use them?

- Photovoltaics produce no carbon dioxide (CO₂) within their operating lifetimes. Using photovoltaics offsets climate altering CO₂ emissions from conventional power plants.
- PVs have no moving parts and require little maintenance.
- Photovoltaics are the renewable energy technology best suited to generating electricity within an urban environment.
- PVs produce electricity where it is used, so energy is not lost moving it around.
- Photovoltaics aid security of energy supply. Use of PV implies many small electricity generators, rather than a few centralised ones. This makes the effects of breakdowns far less dramatic.
- PVs are also independent of the fluctuations in fossil fuel prices, and do not rely on other countries for supply of raw materials.



The sun provides enough energy for all mankind's needs many times over.

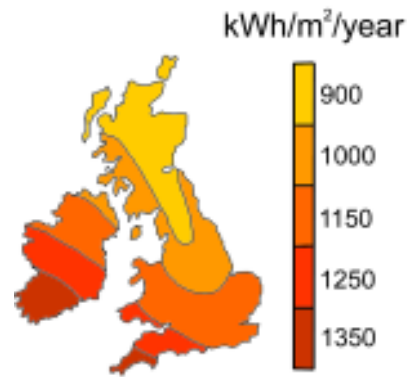

Between 900 and 1300 kWh of energy land on every square metre each year.

		West			South						East			
		-90	-75	-60	-45	-30	-15	0	15	30	45	60	75	90
Inclination (°)	Vertical	90	56	60	64	67	69	71	71	71	69	65	62	58
	80	63	68	72	75	77	79	80	80	79	77	74	69	65
	70	69	74	78	82	85	86	87	87	86	84	80	76	70
	60	74	79	84	87	90	91	93	93	92	89	86	81	76
	50	78	84	88	92	95	96	97	97	96	93	89	85	80
	40	82	86	90	95	97	99	100	99	98	96	92	88	84
	30	86	89	93	96	98	99	100	100	98	96	94	90	86
	20	87	90	93	96	97	98	98	98	97	96	94	91	88
	10	89	91	92	94	95	95	96	95	95	94	93	91	90
	Flat	0	90	90	90	90	90	90	90	90	90	90	90	90

The solar sundial shows the influence of different orientations of the PV array. A wide range of orientations receive more than 90% of the energy of an optimal orientation.

How much energy do we get from the sun?

- The earth receives enough energy from the sun in 15 minutes to power mankind's needs for a whole year.
- Even in the UK, an average of 3 kWh of solar radiation lands on every square metre every day.
- There is a strong seasonal variation. We receive 6 times more solar radiation in summer than winter.
- Regionally, there is a variation from 900 kWh per square metre per year in the north to 1,300 kWh per square metre per year in the south-west.
- By contrast, the average household uses 4,000 kWh of electricity per year.
- But the more you reduce your electricity demand, the smaller the area of PV required.

Influence of orientation

- There are two main components to the solar energy received. Direct light is light from the sun, whilst diffuse light is that scattered off the sky, clouds and surroundings.
- On a clear day, diffuse light is approximately 5% of the total, but on an overcast day this proportion is much higher.
- Because direct light is the major component, photovoltaics should be pointed at the sun for optimum energy production.
- There is a wide range of orientations with near optimal performance. Ideally, photovoltaics should face between south-east and south-west, at an elevation of 30-40°.
- The solar sundial shows the amount of solar energy received for different orientations and roof pitches.
- However, even flat roofs receive 90% of the energy of an optimum array, in the UK.

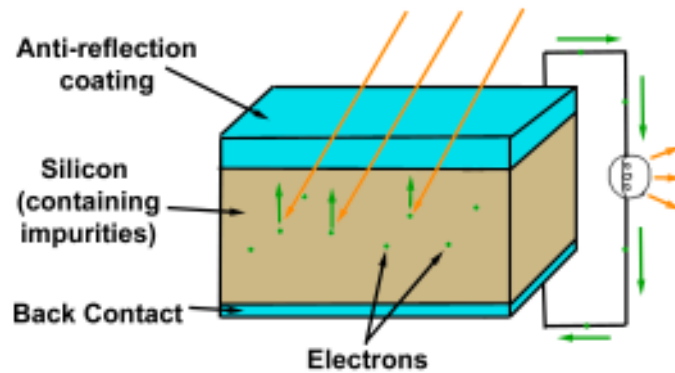

Electrons absorb the energy of the light. Impurities in the silicon force the electrons to move to one surface on the PV material. The electrons flow round an external circuit and give up their energy as useful work.



Christian Jardine

Cells are electrically connected and assembled into modules.



Solar Century

A collection of modules are electrically connected to form a string. One or more strings form an array of modules.

How does PV work?

- When light strikes a photovoltaic device, the energy of the light is transferred to an electron in the PV module.
- Once the electron has gained this energy, it is free to move through the PV panel.
- Photovoltaics are made with two different types of impurities added to the bulk material.
- These impurities force the negatively charged electrons to move to one surface, where they are collected by electrical contacts.
- If wires are connected to these contacts, the electrons can then flow around an external circuit, to the opposite surface of the photovoltaic material.
- In doing so they give up the energy originally gained from light as useful electrical energy.

Components of a PV installation

- The smallest functioning PV component is called a cell.
- Cells are connected together and mounted into modules. Modules are typically either framed or simple laminated structures.
- When modules are connected together in series, they form a string of modules. A collection of strings forms an entire PV array.
- Arrays are connected to an inverter to turn the DC output of the array into AC electricity, for use in the home.
- To avoid expensive batteries for storing electricity, the system can be connected to the electricity grid. Surplus electricity can be sold.
- An array can either use one large 'string inverter', or many smaller 'module inverters'.
- Wiring and support structures are also required, which adds to the cost of an installation.

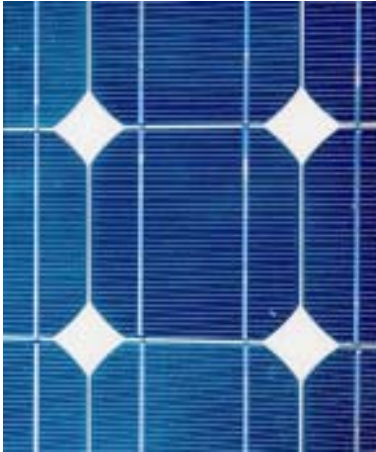

Solar Century

Cells of monocrystalline silicon are characterised by their rounded corners.



Christian Jardine

Monocrystalline BP 585 modules.



Solar Century

Multicrystalline silicon has a dramatic, shimmering appearance.



Gavin Conlbeer

A roof mounted array of multicrystalline silicon modules.

Monocrystalline silicon

- There are many different types of PV technology.
- The highest efficiency commercial cells are made from monocrystalline silicon.
- Typical modules will convert 15% of the solar radiation into electrical energy.
- A pure single crystal of silicon is drawn from a crucible of molten silicon and is then sawn into wafers.
- The wafers are doped and electrical contacts added to form cells, which are then assembled into modules.
- Cells are black or blue, and typically have rounded corners.
- The crystallisation and sawing processes are energy and materially intensive, so monocrystalline silicon modules are expensive.
- Manufacturing can only be performed in batches making this technology poorly suited to mass production.

Multicrystalline silicon

- Instead of growing a pure single crystal, molten silicon is cast in blocks. This results in many randomly oriented crystals of silicon approximately 1 cm in diameter.
- This gives cells a shimmering appearance and imparts a clean, high-tech image.
- Cells are characteristically blue and square.
- Because the crystals are randomly oriented, efficiencies are lower, converting between 8 and 12% of solar energy into electricity.
- It is also possible to draw sheets of silicon from a melt avoiding sawing and making the product cheaper.
- Once again, manufacturing is not well suited to mass production.
- Multicrystalline silicon is cheaper than monocrystalline silicon, but there is a trade off between cost and efficiency.



Christian Jardine

Amorphous silicon modules from Unisolar.



RWE Schott Solar

Amorphous silicon can be made into semitransparent modules.

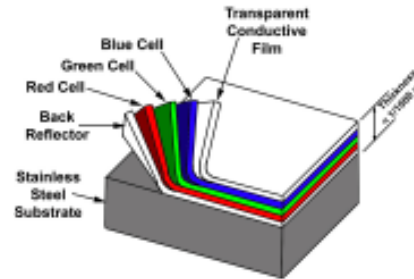

Efficiency can be improved by using different layers, each tuned to a different part of the solar spectrum.



Solar Century

Thin-film materials like amorphous silicon can be mounted on flexible substrates for use on curved surfaces.

Amorphous silicon

- Amorphous silicon has no long range crystal structure, and consequently modules have low efficiencies of between 4 and 6%.
- Laboratory efficiencies are as high as 11.8%, but have not yet been reproduced commercially on large area modules.
- Amorphous silicon modules use very thin layers of material (as little as 1/1000 mm thick). It is referred to as a thin-film technology.
- The amorphous silicon film can be deposited on a backing material such as glass or plastic without the use of high temperatures.
- Modules can be produced directly, so there is no need to electrically connect individual cells, as is the case for crystalline silicon technologies.
- Amorphous silicon is cheap to manufacture, because of low material inputs, low temperature processing and because there is no need for expensive sawing. Because it is well suited to mass-production, costs will drop as production volume increases.
- The highest efficiency (6%) amorphous silicon modules use two or three different layers, each tuned to absorb a different part of the solar spectrum. These are referred to as double- or triple-junction technologies, respectively. This increases the fraction of daylight that can be absorbed by the PV material.
- Because the layers are so thin, it is possible to make flexible panels that can be fitted to curved surfaces.



Christian Jardine

Cadmium telluride offers a high efficiency approach that is capable of being mass produced.



Christian Jardine

Copper indium diselenide is another promising high efficiency thin-film technology.



Christian Jardine

Each of these small arrays has approximately the same W_p rating. The more efficient technologies (monocrystalline silicon, bottom centre) are noticeably smaller than less efficient arrays.

Cadmium telluride and copper indium diselenide

- It is clear that there are cost advantages to thin-film amorphous silicon technology, but efficiencies are low.
- Other semiconducting materials can also be deposited as thin-films.
- Two of the most promising technologies are cadmium telluride and copper indium diselenide.
- Cadmium telluride (CdTe) modules have efficiencies of roughly 7%.
- Copper indium diselenide (CIS) modules have efficiencies of approximately 9%.
- Material costs are higher than for amorphous silicon, and production volumes are currently small (less than 1% of the market). Prices will drop as production volume increases.

What is the peak power rating?

- All modules are sold on the basis of their peak power rating, denoted W_p (Watt peak).
- This is a guide to how much power a PV module can produce under standard test conditions, and so can be used to compare modules of different technology and efficiency.
- For the same peak power rating, a high efficiency technology will have a smaller area than a low efficiency technology.
- For modules of the same size, a higher efficiency technology will have a larger W_p rating.
- The peak power is defined as the power produced under light of 1000 Watts per square metre intensity (as bright as peak sunshine), with the module temperature at 25 °C. The colour of the light is typical of that received outdoors at medium latitudes.
- A PV module will not produce its peak power at all times, as the output depends on the intensity of the light.

Technology	Cost / W_p (£)	Efficiency (%)	Cost / m^2 (£)
Monocrystalline silicon	3.50	15	525
Multicrystalline silicon	2.50-3.50	8-12	200-420
Amorphous silicon	2.00– 3.50	4-6	80-210
Cadmium telluride	3.50	7	250
Copper indium diselenide	4.00	9	360
Marble cladding material			600-1000

Typical production costs of photovoltaic modules.

Costs

- Current production costs for the different PV technologies range between £2 and £4 per W_p .
- Amorphous silicon is cheaper than crystalline silicon.
- Of the crystalline technologies, multicrystalline is cheaper than monocrystalline silicon.
- The other thin-film materials are comparatively expensive, due to low production volumes and the raw materials used.
- Module costs are more variable due to the range of substrates and materials used. Glass laminates, roof tiles and other materials for building integration add cost.
- When designing a system it is important to remember the costs of wiring, inverters, support structures and labour.
- Grants of up to 50% of installation cost are available from the DTI via the Energy Savings Trust. See www.solarpvgrants.co.uk



Building integrated photovoltaics, like these blue tiles, work just like conventional building materials.



Incorporating PV into the building fabric opens up new architectural possibilities.

Building integration

- Building Integrated PV (or BIPV) uses photovoltaics as a conventional building material.
- For example, making a roof out of PV not only produces green electricity, but performs all the insulation and waterproofing features of a conventional roof.
- The cost of the conventional building material can be offset against the photovoltaics (e.g. if you build a PV roof, you save the cost of the normal roof tiles).
- Photovoltaics are not heavy but some extra roofing supports may be necessary.
- At £600-800 per square metre, BIPV products are cheaper than many prestige building cladding materials, such as marble.
- BIPV creates a range of new materials and products for use by architects and designers.

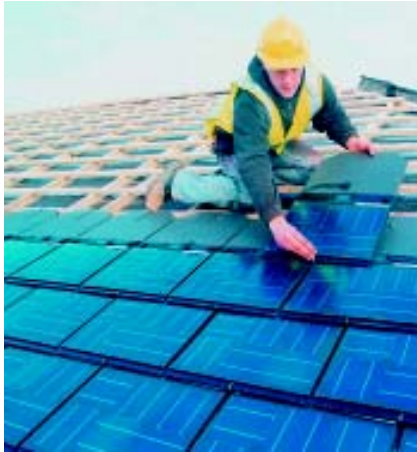

Solar Century

Crystalline silicon solar roof tiles can be installed like conventional roofing materials.



Christian Jardine

Solar shingles of amorphous silicon.



Solar Century

Semi-transparent glass laminates allow natural daylighting and green energy production.

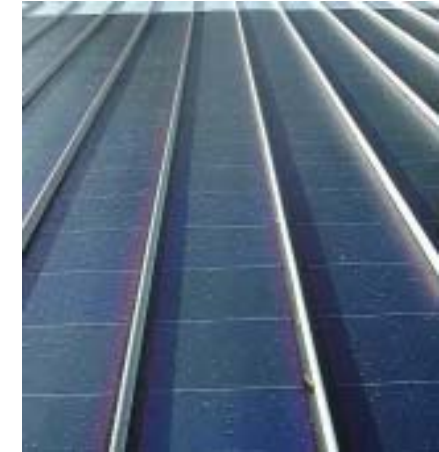

Solar Century

Amorphous silicon integrated into metal seam roofing.

Novel products

- Conventional photovoltaic arrays are built from framed modules mounted on a support structure.
- It is also possible to buy unframed modules, in the form of laminates. These reduce the cost of the module and lower the energy required to make them.
- However, there are also many new products available with a focus on ease of building integration.
- Both crystalline silicon and thin-film technologies have been incorporated into roof tiles.
- Crystalline silicon cells can be inset into roof tiles of a conventional size and shape and are installed in the usual manner.
- Amorphous silicon roof tiles are available as flexible sheets of shingles. These too can be installed by a roofer, with a minimum of training.
- Both amorphous silicon and crystalline silicon wafers have been incorporated into glass laminates. These can be semi-transparent, due to gaps between the cells allowing for a mix of natural daylighting and energy production. Such products allow for a mix of passive solar heating of the building combined with electricity generation.
- Unisolar's triple-junction amorphous silicon technology is available as roll-out sheets that can be bonded to conventional seam-metal roofing.

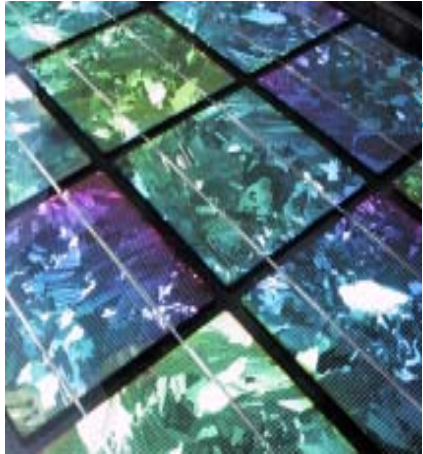

Many different types of solar PV products.....

Which photovoltaic technologies work best in which climates, and why?



...but how well do they work in the UK?

How much electricity will I generate?

- The W_p rating of a module tells us how well it performs in the laboratory under standard test conditions.
- But the W_p rating does not tell us how much electricity it will produce outdoors.
- One might expect products of the same W_p rating to perform identically. However, the electricity produced in one year by different PV modules varies between products. The quantity of energy from a PV array depends on both the technology used (monocrystalline silicon or amorphous silicon *etc.*) and the environmental conditions they are used under (light intensity, temperature, and colour of the received light).
- The car analogy! Similarly, one might expect cars of the same engine size to perform identically. However, they will travel different distances on one litre of petrol. This too depends on both the technology used (aerodynamics *etc.*) and environmental conditions (city or motorway, uphill or downhill *etc.*)
- It is necessary to understand how products respond to these climatic factors to determine which product is best suited to a given application. Best-practice installations are only possible given a thorough understanding of the factors influencing performance.
- The PV-Compare project was established at Oxford University's Environmental Change Institute to determine these influences on performance. The findings of the project are presented in the remaining pages of this report.



Christian Jardine

The UK test site.

Product	Technology	Peak Power (Wp)
Unisolar US64	Amorphous Silicon (Triple Junction)	512
ASE 30 DG-UT	Amorphous Silicon (Double Junction)	576
Solarex Millennia	Amorphous Silicon (Double Junction)	516
Intersolar Gold	Amorphous Silicon (Single Junction)	504
BP Solar 585	Monocrystalline silicon	595
Evergreen ES 112 AC	Multicrystalline silicon (Ribbon)	560
Astropower APX-80	Multicrystalline silicon (APEX Si film)	560
Solarex MSX 64	Multicrystalline silicon	586
ASE 300 DG UT	Multicrystalline silicon (Edge Fed Growth)	600
Siemens ST40	Copper indium diselenide	560
BP Solar Apollo	Cadmium telluride	500 (560 Spain)

Products under test in the PV-Compare project.



Gavin Conibeer

The Mallorcan test site.

The PV-Compare test sites

- Eleven different types of PV modules, covering the range of commercially available technologies, have been mounted on one roof at Begbroke, near Oxford, UK. This enables the products to be tested side-by-side under identical lighting and temperature conditions.
- Uniquely, an identical test site has been built in Mallorca, Spain. This allows us to examine the performance of the PV technologies under a wider range of environmental conditions.
- The results from the PV-Compare project are therefore not site-specific, but are more general and widely applicable to different locations.
- Each product is tested as an array with a rated peak power of approximately $550 W_p$. This makes them typical of a small domestic installation.
- The arrays are connected to inverters, which convert the DC array output into AC electricity for export to the respective national electricity grids. We are using two types of inverter: SMA 700 and NKF OK4E.
- Results presented are related to the rated peak power of the modules. We are using the manufacturer's rated peak power, because this is what consumers see when they purchase PV modules. The PV-Compare project shows how much electricity people can expect to obtain from their purchase.
- Because PV-Compare is a commercially focused test, it is a measure of both the electricity production and the reliability and uniformity of the products under test.
- The energy produced is monitored with respect to the light intensity on the arrays, ambient temperature and module temperatures.

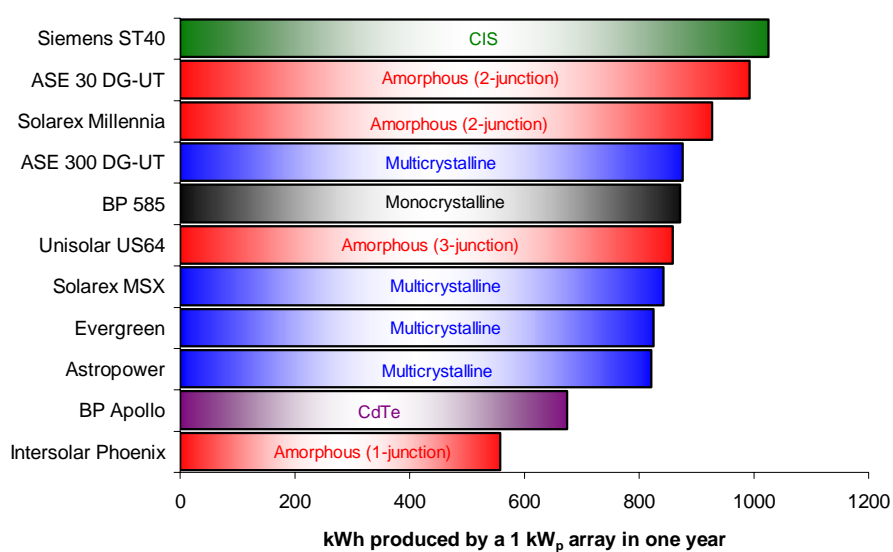

Electricity produced in one year at the UK test site by the different products.

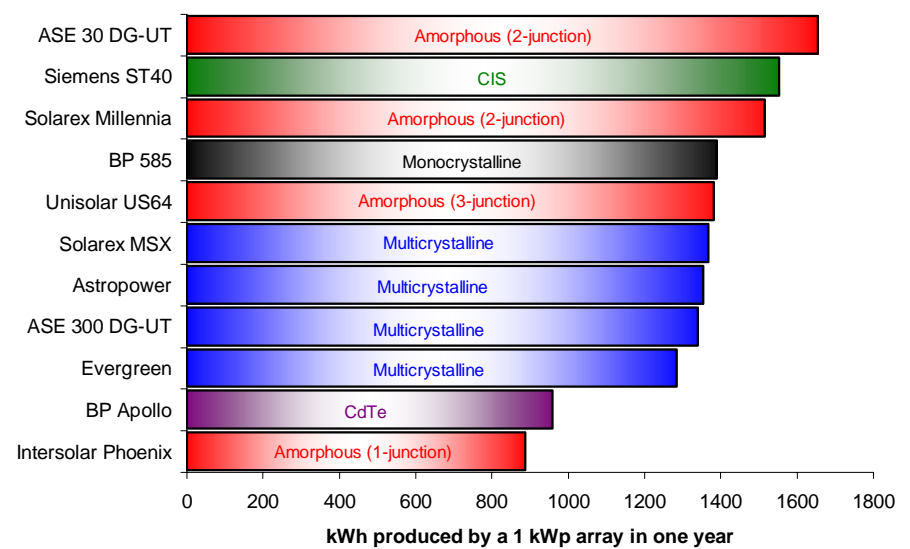

Electricity produced in one year at the Mallorcan test site by the different products.

Which technology produces most energy?

- The UK array produced an average of 5,197 kWh from 1022 kWh/m² radiation per year. The Mallorcan array produced 8,052 kWh per year from an annual radiation of 1,700 kWh/m². The array in the UK is more efficient than the array in Mallorca, mainly due to the lower operating temperatures in our cooler climate.
- The Mallorcan array produces more electricity than the UK array at all times of year. However, in the summer months this is only marginal as the longer day length at more northerly latitudes compensates for the lower light intensities in the UK.
- The number of kWh of electricity produced by a 1 kW_p PV array varies widely between the different products in both Mallorca and the UK. The highest yielding modules produce nearly twice as much energy as the lowest yielding modules. This is a serious concern to consumers, who would expect similar yields from different products of the same W_p rating.

- In the UK, CIS gives the best returns of over 1000 kWh/kW_p per year. This is followed by the double junction amorphous silicon technologies. Triple junction amorphous silicon did not perform as well as the double junction products. There is little to choose between the crystalline silicon products (mono and multi-crystalline). The lowest yielding modules were made from cadmium telluride and single junction amorphous silicon.
- In Mallorca, double junction amorphous silicon and CIS products gave the highest returns of energy per W_p. The crystalline silicon technologies all give similar performance and triple junction amorphous silicon was comparable to this. Once again, the lowest yielding modules were cadmium telluride and single junction amorphous silicon.

The best performing technologies yield up to 20% more energy per kW_p than conventional crystalline silicon arrays. It is essential that customers are aware of this when purchasing PV.

Product	Technology	Mallorca		Oxford	
		kWh/kW_p	kWh/m^2	kWh/kW_p	kWh/m^2
Unisolar US64	Amorphous	1380.4	87.3	858.6	54.3
ASE 30 DG-UT	Amorphous	1655.3	88.3	991.8	52.9
Solarex Millennia	Amorphous	1515.5	79.8	926.6	48.8
Intersolar Phoenix	Amorphous	887.4	38.9	557.3	22.3
BP 585	Monocrystalline	1389.2	187.9	871.8	117.2
Evergreen	Multicrystalline	1283.3	94.6	824.8	60.8
Astropower	Multicrystalline	1352.9	88.1	821.8	61.2
Solarex MSX	Multicrystalline	1368.0	143.1	842.0	96.2
ASE 300DGUT	Multicrystalline	1340.4	155.9	875.1	101.8
Siemens ST40	CIS	1553.3	150.3	1025.3	99.2
BP Apollo	CdTe	958.5	64.8	673.7	48.9

Annual energy yields of the different technologies.

- Amorphous silicon products are cheaper per W_p than crystalline products, and in general return more energy.
- Further laboratory tests have shown that the single junction amorphous silicon Intersolar Phoenix had suffered degradation explaining the low yields.
- The BP Apollo, made from cadmium telluride was at a prototype stage when installed as part of the PV-Compare project. Current modules are likely to give significantly higher yields comparable to crystalline silicon.
- The Unisolar US64 showed variations in power output between modules. The poorer modules limit the performance of the better modules in a string, resulting in the energy yields of this triple junction amorphous silicon being lower than the double junction amorphous silicon. The manufacturer claims that the problem has been solved for the latest production runs.

How much electricity is produced per square metre?

- When designing photovoltaic installation it is also useful to know how much electricity is produced per square metre per year.
- The amount of electricity produced per square metre reflects the efficiencies of the technologies. The highest returns of energy per unit area were produced by the highest efficiency products.
- The monocrystalline silicon BP 585 produced the most electricity per m^2 , although the Siemens ST40, made from CIS, and some multicrystalline arrays also gave high yields.
- The multicrystalline silicon modules showed a wide range of yields per unit area, with Astropower and Evergreen products operating with low efficiencies being only marginally better than the best amorphous silicon devices.

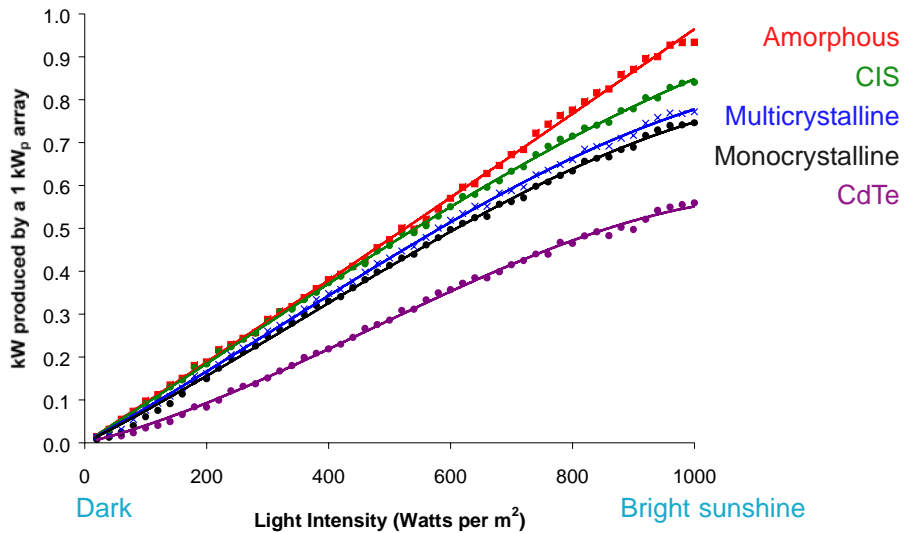

The power generated by these representative arrays increases with light intensity. There are some subtle variations due to temperature and colour of the received light.

How does power vary with sunshine?

- The power produced by a PV array increases with the intensity of the light striking it.
- However, crystalline silicon, CdTe and CIS all produce relatively less power than amorphous silicon at high light intensities.
- High light intensities are found in bright clear conditions, which is also when temperatures tend to be highest. Amorphous silicon does not drop significantly in performance under high temperatures, whilst the other technologies do.
- Amorphous silicon and CIS also perform relatively well at low light intensities. Low light intensity conditions are often found under overcast skies. The light under such conditions is primarily diffuse, which is bluer in colour. Only amorphous silicon and CIS are capable of absorbing light of this hue.

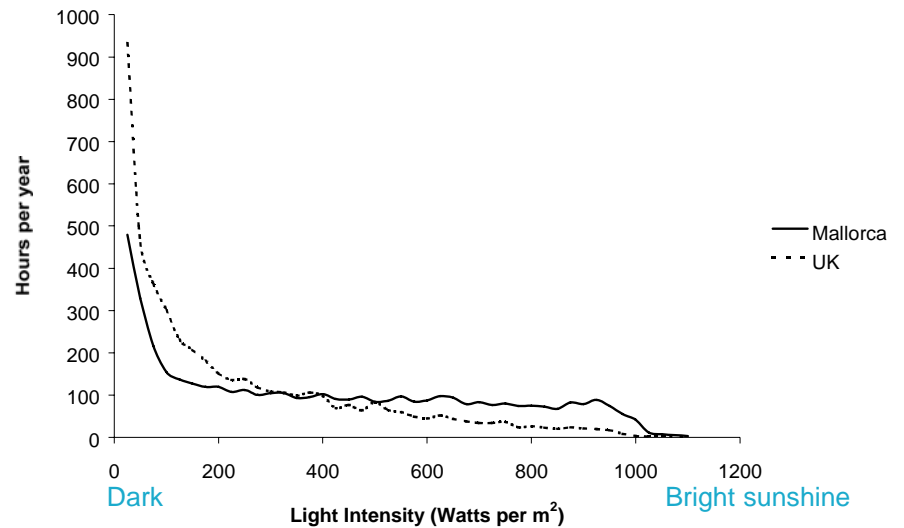

Climatic conditions in the UK are dominated by low light levels due to high cloud cover.

What are the lighting conditions like?

- In both Oxford and Mallorca, most time is spent at low light levels between 0 and 200 Watts per m². This is because every day has its dawn and dusk, as well as times when it is overcast.
- In Mallorca, roughly constant amounts of time are spent at light intensities between 200 and 1000 Watts per m².
- Lighting conditions in the Oxford are heavily skewed towards low light intensities. Unsurprisingly, this is due to the greater extent of cloud cover in the UK.
- Light intensities in the Oxford never reach as high as in Mallorca because the sun never gets as high in the sky.
- Mallorca is typical of a Mediterranean climate and Oxford is representative of the UK. To see the effect of different locations in the UK, look at the solar radiation map on page 4.

Multijunction amorphous silicon outperforms other technologies here

Amorphous
CIS
Multicrystalline
Monocrystalline
CdTe

Dark

Bright sunshine

In Mallorca, the majority of energy is produced under bright, clear sky conditions.

Under what conditions is the electricity produced?

- These graphs show how much electricity is produced at a particular light intensity over the course of one year. The area under each curve is the total energy output per year from that array.
- The lines look jagged due to random variations in the occurrence of different light intensities over the course of the monitoring.
- In Mallorca, most electricity is produced under bright lighting conditions. The double and triple junction amorphous silicon arrays outperform the crystalline silicon arrays because they perform better at high light intensities. High light intensities are found alongside high temperatures. Amorphous silicon does not lose efficiency under high temperature conditions, unlike the other materials.

Multijunction amorphous silicon and CIS outperform other technologies here

Amorphous
CIS
Multicrystalline
Monocrystalline
CdTe

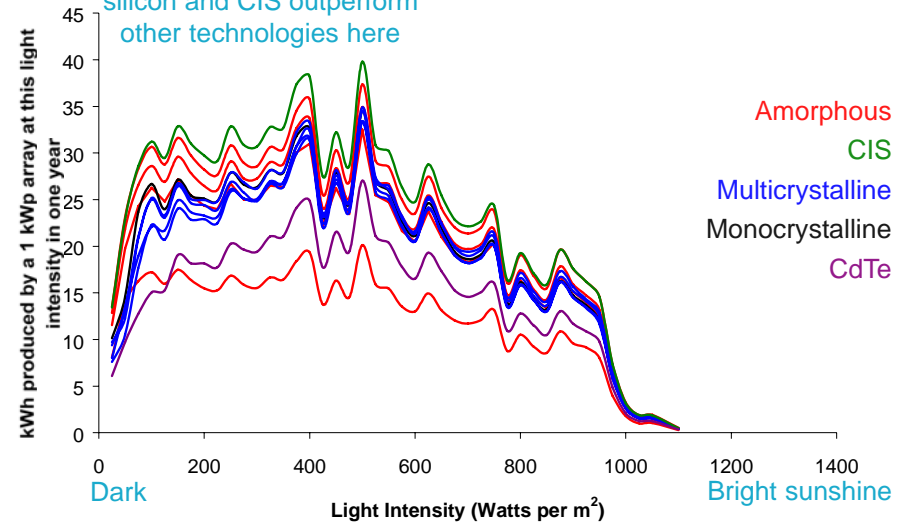

In the UK, the majority of the energy is produced under overcast, low light intensity conditions.

- In Oxford, most electricity is produced under low to medium light intensities. Low light intensity conditions are dominated by overcast light, which is bluer than clear sky conditions. Amorphous silicon and CIS are the only technologies capable of efficient absorption of blue light, so these technologies outperform the crystalline silicon and cadmium telluride arrays.
- Temperatures in Oxford are typically 5°C cooler than in Mallorca. This benefits the crystalline silicon, cadmium telluride and CIS technologies.
- CIS benefits from both the lower operating temperatures and high cloud cover in the UK, making it the best suited to our climate.
- Whilst we see similar rankings in relative energy production in the UK and Mallorca, this is coincidental because the reasons are different.

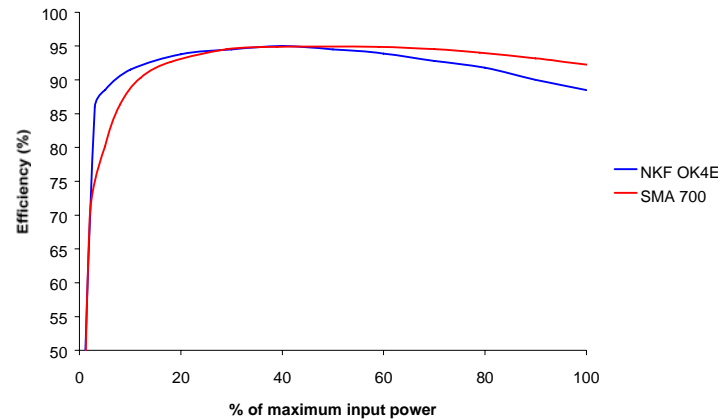
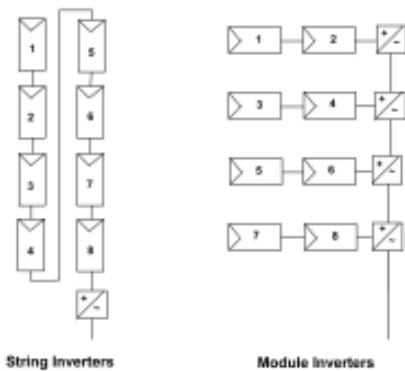

	SMA700	NKFOK4E
Mallorca	94.5	92.5
UK	92.3	92.0

String and module inverter approaches for converting DC to AC electricity.

The inverter efficiencies of the two inverter types as a function of the input power.

Average annual inverter efficiencies under 'real-life' operating conditions.

Converting the electricity to AC

- The PV-Compare project uses two different types of inverter to convert the DC output of the PV modules into AC electricity for export to the electricity grid and for use in the home
- The SMA 700 is used as a string inverter with many PV modules strung together and connected to one central inverter.
- The NKF OK4E is used as a module inverter as each module (occasionally several) has its own inverter.
- The efficiency of the inverter varies with the power going into it.
- Both string and module inverters convert at roughly 90% at most powers, but both drop away sharply at low power inputs.
- The NKF inverters are relatively more efficient at low power inputs, and the SMA more efficient at high power inputs.
- In the UK, most electricity is produced by the PV modules at low light intensities (*i.e.* low power inputs). The NKF inverters are better matched to the UK climate as they convert most efficiently at low power inputs, but they do not have the overall efficiency of the SMA inverters.
- High efficiencies at low input powers is an important consideration when choosing inverters for use in the UK.
- Because most electricity is produced at high insulations in Mallorca (*i.e.* high power inputs), both inverters operate more efficiently in the Mallorcan climate. The SMA inverters are particularly well matched to the Mallorcan climate, as they operate very efficiently at high power inputs where the majority of the energy is produced.



Solar Century

Photovoltaics are an elegant, urban-based method of generating green electricity.

PV produces energy where it is used.



Solar Century

Grid-connection allows PV owners to sell surplus electricity.

Conclusions

- Photovoltaics generate electricity from daylight, and generate substantial quantities of energy even in the UK.
- Although more electricity is generated when sunny, much electricity can be produced under overcast conditions.
- They are an excellent method of reducing climate changing CO₂ emissions, and are the renewable energy technology best suited for use within the urban environment.
- Generating electricity from your own roof brings independence from the electricity grid and protects from future price rises.
- The orientation of the panels does not have a significant influence on output within a wide range of positions because much of the received light is diffuse.
- There are many different photovoltaic products on the market, but there is a lack of knowledge about their performance.
- Electricity can be produced from PV technology incorporated into tiles, shingles and glass laminates as well as standard modules. The cost of such building integrated products is offset by replacing conventional materials.
- Some PV modules are flexible and can be mounted on curved surfaces.
- Most roofers could install a PV array, given the requisite skills and training. However, connection to the grid requires the permission of your local electricity company.
- The electricity produced should be used within the home first, where it is more valuable. Any surplus electricity can be sold to the grid, but is not always as cost effective.



Christian Jardine

Amorphous silicon and copper indium diselenide products yield the most energy in the UK. This is because they can absorb more light when it's cloudy.

Amorphous silicon modules like these Solarex Millennia cope well with cloudy conditions.



Solar Century

Monocrystalline silicon produces the highest yields of electricity per unit area.

PV-Compare conclusions

- Different products of the same W_p rating produce a wide range of quantities of electricity in one year. This is not transparent to the consumer.
- Three technologies exhibited design problems that hampered performance, but manufacturing reliability is improving all the time.
- In the UK, copper indium diselenide and double-junction amorphous silicon produce the most energy per W_p . These technologies are capable of absorbing blue light, found under overcast skies, which are prevalent in the UK. These technologies are actually more efficient in cloudy light than bright sunshine!
- In Mallorca, double-junction amorphous silicon gives the greatest returns of energy per W_p . This is because it is relatively unaffected by the high temperatures found under bright light conditions.
- Monocrystalline silicon and copper indium diselenide give the highest yields of energy per unit area. These present a good option for applications where space is limited or energy yields need to be maximised.
- Multicrystalline silicon does not yield as much energy per W_p as other technologies, but it is a highly attractive product well suited for applications where a clean, high-tech image is desired. Multicrystalline products vary widely in the amount of energy delivered per unit area.
- The SMA 700 string inverters have higher overall conversion efficiencies than the NKF OK4E module inverters. However, the module inverters have relatively higher efficiencies at low power inputs (low light intensity) and are better matched to the UK climate.

Environmental Change Institute

The Environmental Change Institute was established at Oxford University to organise and promote collaborative interdisciplinary research on the nature, causes and impacts of environmental change, and to contribute to management strategies for reducing future environmental change.

The Lower Carbon Futures research team is examining methods for reducing CO₂ emissions from the domestic sector of the UK economy by a combination of increased energy efficiency and renewable energy sources. Led by Brenda Boardman, the group's work is a mix of technology, policy and user perceptions.

The PV-Compare project has been running at the ECI since 1999. It has determined which photovoltaic technologies are best suited for use in the UK: an important step in developing a mass market for PV in this country. For a full technical report of the PV-Compare project, contact the address or website below.

Authors

Dr. Christian N. Jardine: Research Fellow at the Environmental Change Institute (2001-present). Chris's research has focussed on studying the relationship between the electronic structure of molecules and their reactivity. The PV-Compare project continues this theme by examining the relationship between PV materials and their electrical output under outdoor operating conditions. However, PV-Compare is a commercially focussed project, which aims to help develop a strong UK PV sector, and embraces a raft of technical, social and policy aspects necessary for effective market penetration.

Dr. Kevin Lane: Research Fellow at the Environmental Change Institute (1994-present). Kevin's work is principally involved in modelling and examining policy options for reducing carbon emissions. This initially involved examining opportunities for reducing carbon emissions by using fossil fuel more efficiently, but more recently has expanded to include the examination of new and renewable technologies.

PV-Compare Sponsors

Solar Century: a solar PV solutions business designs, installs and maintains tailor-made solar PV systems for businesses, homes, industry and the public sector.
<http://www.solarcentury.co.uk/>

The BOC Foundation. Established by The BOC Group plc in 1990, the Foundation awards grants for projects proposing practical solutions to environmental problems in the UK.
<http://www.boc.com/foundation/index.html>

This booklet is kindly sponsored by the Royal Institute of British Architects

Further funding has come from the Charterhouse Foundation and the Avina Foundation.

ECI Research Report 27

Lower Carbon Futures Research Group
Environmental Change Institute
University of Oxford
5, South Parks Road,
Oxford OX1 3UB
United Kingdom

Tel: +44 1865 281180
Fax: +44 1865 281202
E-mail: Administrator@eci.ox.ac.uk
Website: www.eci.ox.ac.uk

Printed February 2003
© University of Oxford
ISBN: 1-874370 35 4
£10 inc. p+p

